

## AC SOLAR GENERATOR WITHOUT INVERTER

Vaishnavi Bhalkar\*<sup>1</sup>, Vasudha Gurav\*<sup>2</sup>, Bhakti Valake\*<sup>3</sup>, Vishwajeet Patil\*<sup>4</sup>,  
Abhijit Ghatage\*<sup>5</sup>, N. S. Jadhav\*<sup>6</sup>

\*<sup>1,2,3,4,5</sup>Student, Electrical Engineering, Sanjeevan Engineering and Technology Institute, Panhala, Maharashtra

\*<sup>6</sup>Professor, Sanjeevan Engineering and Technology Institute, Panhala, Maharashtra

### ABSTRACT

Today, a greater part of the world's energy needs are met by petroleum products and as the worldwide energy utilization increments definitely so does the utilization of petroleum products. Be that as it may, petroleum derivatives being a non-sustainable asset is nearly consumption and subsequently emerges the requirement for the utilization of sustainable power assets. The task attempted, advances an inventive method for creating power from sun oriented energy utilizing sun powered chargers by straight forwardly producing AC power, not at all like the regular frameworks which creates DC power which must be further on changed over to AC. This new framework, eliminates the requirement for inverters and stage synchronizers, the misfortunes brought about by the influence electronic converters and need for batteries. Making the framework more savvy, effective and pragmatic. The framework utilize a array of photovoltaic cell pairs which are associated in antiparallel structure to make an AC wave structure. The frequency of the AC output created by these cells as they are on the other hand covered and presented to sun powered rate under a turning plate can be controlled, by just controlling the speed of the motor used to rotate the disc.

**Keywords:** Solar, AC Power, Disk, Photovoltaic, Frequency

### I. INTRODUCTION

The necessity of environmentally friendly power is expanding as the overall environment is changing step by step. Coal and other petroleum derivatives are likewise restricted and they will at last run out. The hydroelectric power can be a restricted wellspring of energy it must be utilized in places with gigantic water assets. Then, at that point, thermal power can likewise be utilized for the generation of electricity yet it can make atomic waste so it isn't ecological cordial. However, the utilization of clean sustainable power as sun oriented energy is conceivable. It is an ordinary asset of clean energy as sun sparkles wherever in the planet. So it is not difficult to change over sun oriented energy into power utilizing a sun based cells. Sun based power is expected to turn into the world's biggest wellspring of power by 2050, with sunlight based photovoltaic and concentrated sun oriented power contributing 16 and 11 percent to the worldwide generally speaking utilization. A Photovoltaic cell is comprised of a semiconductor material like silicon. It retains the daylight and produces power. Electron can stream in a one heading through a solar cell on the grounds that the terminals (positive and negative) of the solar cell are static. That is the reason solar cell can create direct current (DC). The essential issue with sunlight based power age is that, sun powered chargers today produce DC power which must be changed over to AC as a larger part of the electrical gadgets can utilize alternating current (AC). The cost of sun powered chargers joined with the cost of inverters, stage synchronizers, establishment and support has made the cost of sun oriented restrictive. Add to that the deficiency of force from the various parts utilized in the DC to AC transformation cycle and it becomes much more ugly. Today, AC power is created for the power lattice by AC generators. The generators are controlled by mechanical energy given by water turbines or steam turbines, flammable gas or atomic fuel. The mechanical energy turns the curls of the generator in an attractive field to deliver voltage. Since the guide loop of the generator flips heading during revolution in the attractive field the subsequent voltage delivered is sinusoidal or AC. This venture disposes of the issue of switching DC over completely to AC. It utilizes sun powered as its feedback and with the assistance of an motor disc arrangement it changes over the DC force of sun oriented cells straightforwardly to AC without utilization of any transformation gear. The coming about yield voltage is hence sinusoidal or AC. In this manner there is no need of transformation hardware's like inverters, stage synchronizers and so forth. This makes the general idea very basic yet successful and affordable as well. And, these sunlight based AC power generator exhibits can undoubtedly supplant the power establishes today, simultaneously being nature well disposed, they can be found any place like in a playground, school or in any private or in any metropolitan environmental

# Digital Smart Pen

Akshay Vilas Aswale<sup>1</sup>, Abhijit Balaso Kumbhar<sup>2</sup>, Mayuresh Mohan Desai<sup>3</sup>,

Aditya Sudhir Shigavkar<sup>4</sup>, Abhishek Bhaskar Mane<sup>5</sup>, Prof. Y. R. Naik<sup>6</sup>

Student, Electrical Engineering Sanjeevan Engineering & Technology Institute<sup>12345</sup> Professor, Electrical Engineering Sanjeevan Engineering & Technology Institute<sup>6</sup>

**Abstract: The purpose of education and learning is often defeated when gadgets developed to assist in the process of learning is not user friendly or ends up becoming a distraction in the classroom due to its size. This work intends to describe a gadget known as smart pen which is a new and evolving technology that does not create distraction due to its portability, that is user friendly and above all its affordable nature. Just like any other pen, it is a writing device developed by the Livescribe company. It is a digital and intelligent pen that is fast gaining recognition in synchronizing written notes.**

## I Introduction

Smart pen is a more specific term; it has the same basic characteristics, but also has other features like voice recording or a text scanner. Digital pens typically contain internal electronics and have features such as touch sensitivity, input buttons, memory for storing handwriting data and transmission capabilities. A digital pen is an input device which captures the handwriting or brush strokes of a user and converts handwritten analog information created using "pen and paper" into digital data, enabling the data to be utilized in various applications. This type of pen is usually used in conjunction with a digital notebook, although the data can also be used for different applications or simply as a graphic. We talk about an increasingly common writing technology called Smart pen. Being one of the latest and useful gadgets on the market today, this practical tool's only purpose is to make our life easier. It is small and compact, it is helpful in more than one way and it can be used by just about anyone.

The Live scribe Echo Digital Smart pen is a very ingenious pen that not only can write but records too. This pen not only writes like any other pen but it also hears and keeps the information we know that is important and do not want to forget. Recording is done by simply tapping the record button in the

notebook to start and tapping again to stop. Through the standard cable it is possible to connect the pen to the computer, which passes all the recordings and also turns possible the search to find both verbal and written notes "Digital pens also called smart pens are made of internal electronics with touch sensitivity, input buttons, transmission capabilities, and also memory for storing handwriting data. With such features, it's able to convert handwritten data into digital data . "Digital pens are usually connected to the computer or pads via Bluetooth or USB cables, they offer more functions compared to a stylus. The sensors fit in the digital pens to detect motion and then translate the motion into graphics, art or writing. Mostly used by graphic designers to make drawings and sketches on their computers while for some students they take notes using digital pens." "Digital pens have features like touch sensitivity, memory, input buttons and electronic erasing capability. A digital pen can be used to write on digital paper, and once done, the user can save what has been written. The pen usually vibrates or beeps as a sign of confirmation that the user has finished a page and the work has been saved. Most digital pens save handwritten work as images in the commonly used GIF or JPEG format. Some, however, use a proprietary format. There are various types of digital pens available on the market like the trackball pen (with a sensor attached to detect the motion of the trackball), camera pen (with camera attached), positional pen (to detect the position of the tip) and active pen. All of these have some special features to differentiate them." "Live scribe's Smart pens are also audio recorders so that students can capture the lectures with their notes. By pointing the Smart pen to their writing or drawings on the digital paper, they can play back the lecture they were listening to when they made those entries. " "An electronic ballpoint pen that digitizes, stores and transfers what is written or drawn to the computer. Instead of a mouse, a digital pen

## SOLAR-WIND HYBRID ENERGY SYSTEM FOR DC LIGHTNING

**Shubham Narke<sup>\*1</sup>, Kunal Gavali<sup>\*2</sup>, Pradip Kadam<sup>\*3</sup>, Aditya Bhosale<sup>\*4</sup>,  
Pradeep Dange<sup>\*5</sup>, Yogesh R. Naik<sup>\*6</sup>**

<sup>\*1,2,3,4,5</sup>Students, Sanjeevan Engineering & Technology Institute, Panhala, Maharashtra,  
Sanjeevan Engineering & Technology Institute, Panhala, Maharashtra, India.

<sup>\*6</sup>Professor, Sanjeevan Engineering & Technology Institute, Panhala, Maharashtra,  
Sanjeevan Engineering & Technology Institute, Panhala, Maharashtra, India.

### ABSTRACT

Now days energy demand is continuous Increasing because of population growth, Advancement in technology. The conventional Sources are available in limited manner & they Have adverse effect on the environment. Whereas non-conventional sources available Naturally with free of cost & does not have any Adverse effect on the environment. In proposed system we have implemented “Solar Wind Hybrid Energy System for DC Lightning.” This system is mainly applicable for residential or commercial application, in the remote areas, in hilly areas where electricity is not available.

### I. INTRODUCTION

Hybrid system means electricity generation by using two or more sources. The generation of electrical energy by using solar and wind energy called solar wind hybrid system. As we know availability of energy changes as Seasons changes. In summer Seasons there are maximum availability of sun rays and in a rainy or winter Seasons there are maximum availability of wind energy. The availability of energy also changes with day, means at the day time maximum availability of sun energy and at the time of evening maximum availability of wind energy. The generation of electrical energy by using only one system either through solar energy or through wind energy does not provides that much reliability. As if we use hybrid system it provides reliable system. In Proposed system in summer seasons maximum energy generated through solar system whereas in rainy or winter Seasons maximum energy generated through wind system. In such way this system provides reliable supply throughout the year. Now a days energy demand is continuously increasing because of a population and advancement in the technology. now a days most of energy generated through the conventional energy sources. But their availability Limited in nature and they are at the exhausting phase they produce pollution and having adverse effect on the environment. Whereas renewable energy available in abundant manner with free of cost in the environment, they are eco -friendly and does not produce any pollution and don't have any adverse effect on the environment. So Renewable Energy Sources are best choice for the generation of electrical energy.

### II. METHODOLOGY

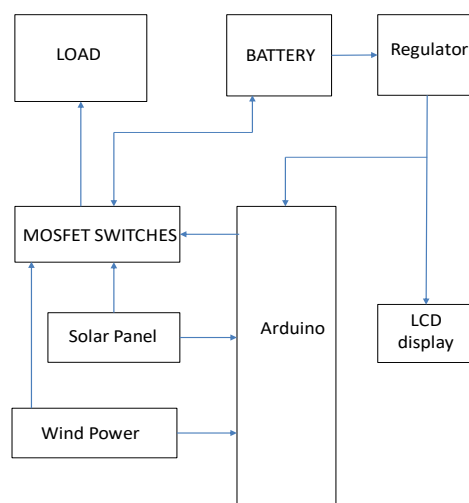

**Fig 1:** Block Diagram of Selector Circuit\_Hybrid system.

# Smart Irrigation System

Vaishnavi Gavali<sup>1</sup>, Rutuja Pawar<sup>2</sup>, Neha Nikam<sup>3</sup>, Sushant Patil<sup>4</sup>, Prof. V.T. Metakari<sup>5</sup>

<sup>1,2,3,4</sup>Department of Electrical Engineering, Sanjeevan Engineering Technology & Institute, Panhala, Maharashtra, India.

Submitted: 15-06-2022

Revised: 25-06-2022

Accepted: 27-06-2022

## ABSTRACT

This paper deals with innovative technology in various ways to irrigate agricultural land using solar power. By using this system we can find suitability/humidity in the soil. And also we find the surrounding Temperature & humidity in air by using sensor. The main purpose of this paper provides irrigation by knowing the soil moisture. This system saves the energy and power and it is very important in future. We will use this project in countries where there is of water seems be in short for agriculture.

**Keywords:** Soil, Moisture sensor, Humidity sensor, Temperature, Arduino, Solar Panel.

## I. INTRODUCTION

The contribution of agriculture sector to the Indian economy is huge. The Use of manpower should not be excessive and these techniques need to be used to maximize profits over time. Nowadays the demand for energy is increasing and there is a constant flow of fuel into existing sources. And Sources and pollution is on the rise and forcing mankind to take up new, unconventional energy resources like solar energy, wind energy. Development of these new technologies is achieving our goal of sustainable development.

1] Photovoltaic pumping can be installed anywhere. And they can take care of five to ten years. Because they need less maintenance so it also reduces costs. 2] In the past irrigation method is major reason for this old method to imitate the crop in a traditional way without knowing the right Crop ratio, thus destroying some crops.3] We use this project to solve the problem. Due to the growth of the world's population, the growth of agriculture needs to be increased and on the other hand, due to the increasing demand for food due to the population, Farmers are facing many problems. 4] It can control the pump using Arduino based on an Arduino UNO based Automatic irrigation system in this project we have added soil moisture sensor, humidity sensor & Temperature sensor. To the input voltage signal of the input sense the moisture in the soil as well as sense the air& temperature of surrounding area. 5 ]You can also use the GSM model in this project. Using of this model we can do your motors off at home. 6] This project provides information by Arduino using sensors, when the soil is dry then motor is on when soil is wet then motor is automatically off it is displayed on LCD. 7] Solar Panels are generally known photovoltaic or PV panels. In solar conversion of sunlight in electricity & this electricity stored by battery. It is used to operate electrical equipment and power equipment.

# Reverse Recovery of Motor Shubham Mane, Shivraj Mali, Niral Dand

1flat No 1 Anant Plaza Kagal  
2grampanchayat Chouk Unchgaon  
3shahupuri 1<sup>st</sup> Lane Kolhapur  
PROF. P. B. GURAV,  
ELECTRICAL ENGG DEPARTMENT, SETI PANHALA

---

Submitted: 01-07-2022

Revised: 04-07-2022

Accepted: 08-07-2022

---

**ABSTRACT** - In today's world industrialization is growing very fast, there are many types of industries particularly manufacturing and process industries need three phase induction motor for their process work. Three phase induction motor plays very important role in industries. Reversal of motor is a crucial problem in the industries, normally VFD method is used to control reversal of motor but it is very expensive. By use of few electronic components, we can solve this problem. The use of this project is to avoid the damages of driven equipment due to rotation in reverse direction. To find optimum and cost effective solution for reverse rotation detector instead of bigger and costly panel, To demonstrate the solution of reverse rotation which we can use for any type of motor or rotating equipment.

**Keywords-** motor, reverse rotation, control

## I. INTRODUCTION

If driven equipment is rotate in reverse direction, then it may cause the damage of driven equipment or the damage the output of the driven equipment. To avoid this we may use this reverse rotation device which is avoid the reverse rotation of 3Ph induction motor which is majorly used in industry by using microcontroller & proximity sensors. This is cost effective solution instead of bigger control panel & we can use same for any type & rating of motor. Electric motor is an electrical machine that converts electrical energy into mechanical energy. Most electric motors operate through the interaction between the motor's magnetic field and electric current in a wire winding to generate force in the form of torque applied on the motor's shaft. Electric motors can be powered by direct current (DC) sources, such as from batteries, or rectifiers, or by alternating current (AC) sources, such as a power grid, inverters or electrical generators. An electric generator is mechanically identical to an electric motor, but operates with a reversed flow of

power, converting mechanical energy into electrical energy

## 1.1 OBJECTIVES

The objective of the project reverse recovery of motor has 'to protect the motor from rotate in opposite direction'. Main purpose of this project will be to stop motor to rotate in reverse direction. In present time to overcome this situation VFD are used, which are very high priced. In our project we are doing this work in very cost-effective price and easy to operate

## II. LITERATURE SURVEY

Author yen-chuan chang and ying-yu tzou presents a new sensor less starting method for brushless DC motors without reversing rotation for unidirectional applications. The method can detect the rotor position at standstill and a specific start-up method is then used to accelerate the motor up to a middle-speed where conventional sensor less control algorithms based on the back-EMF can work properly. The proposed scheme employs only one current sensor at DC-link side of the inverter, and can be applied to a motor without knowing its parameters and additional position sensors. As compared with previous approaches, the presented technique can simplify the sensor less position detection procedure and lower the cost. The proposed initial rotor position detection technique has a resolution of 30 electrical degrees, and does not cause any rotor vibration during the detection process. The sensor less starting scheme has been implemented on a single-chip DSP controller (TMS320LF2407A) and experimental results reveal that the starting procedure can work smoothly without temporarily reversing rotation

Ching-Tai Chiang discusses the influence of reverse rotating field on the vibration of separated phase

## SMART BLIND STICK

Sneha Patil\*1, Uday Patil\*2, Pratik Patil\*3, Najim Mullani\*4,

Sangram Bhosale\*5, Prof. N.S Jadhav\*6

\*1,2,3,4,5 Students, Department of Electrical Engineering, Sanjeevan Engineering and Technology Institute Panhala (Maharashtra, India).

\*6 Assistant Professor, Department of Electrical Engineering, Sanjeevan Engineering and Technology Institute Panhala (Maharashtra, India).

### ABSTRACT

Nowadays, there is a need for a Private Mentor for a blind person. This project presents a smart stick for a blind person. Most of us, who are normal and healthy can reach the destination easily but visually impaired people who cannot Walk independently face problems in their daily lives. They will be in need of continuous help and companionship till they reach their desired destination. This System is designed to detect the obstacle and provides the live location of a person in case a person goes out of the desired location. Whenever an obstacle is found in the path of a blind person, it alerts him through a buzzer, and in case of an emergency, the exact location of the person is tracked by GPS and sent to the caretaker through the GSM module. There is a continuous ongoing interaction between the microcontroller and these modules. So, when the switch is pressed, the GPS module tracks the latitude and longitude of the location where the blind person is standing and sends it to the microcontroller which converts it to a form of Google map link and sends it to the predefined mobile number of the caretaker with the help of the GSM module. The Ultrasonic sensor frequently senses the obstacles within the corresponding range which is set in the Arduino. If any obstacles are found, create a buzzer sound with the vibration of the blind stick so that it can alert the blind person about his surroundings. This system cost is less, gives a fast response, is easy to handle, and is affordable to blind persons.

**Keywords:** GSM, GPS, Microcontroller, Sensors.

### I. INTRODUCTION

A survey by WHO (World Health Organization) carried out in 2011 estimates that in the world, about 1% of the human population is visually impaired (about 70 million people) and amongst them, about 10% are fully blind (about 7 million people) and 90% (about 63 million people) with low vision. The main problem with blind people is how to navigate their way to wherever they want to go. Such people need assistance from others with good eyesight.

These days, visually impaired people deteriorate from serious visual impairments preventing them from traveling individually. In like manner, they need to use a wide range of tools and techniques to help them in their mobility. One of these techniques is orientation and mobility specialist which helps the visually impaired and blind people and trains them to move on their own independently and safely depending on their other remaining senses. Recently, many techniques have been developed to enhance the mobility of blind people that rely on signal processing and sensor technology.

We are providing a solution to this by presenting the "Smart Blind Stick". This stick consists of various sensors like an ultrasonic sensor, a water sensor with a GPS-GSM module, and with Arduino board with an integrated Atmega 328 microcontroller. The sensor senses the obstacle and gives a signal to Arduino and notifies the user through a buzzer. GPS gives the location of the blind person in case the person goes out of the convenient location. In this system, GSM will help to track the location of the person handling the stick.

# IOT Based Smart Food Dryer

Rohit Anil Koli<sup>1</sup>, Rushikesh Deepak Patil<sup>2</sup>,

Omkar Rajkumar Wale<sup>3</sup>, Prof. P.P.Kulkarni<sup>4</sup>

Student, Electrical Engineering Sanjeevan Engineering & Technology Institute<sup>123</sup>

Professor, Electrical Engineering Sanjeevan Engineering & Technology Institute<sup>4</sup>

**Abstract:** The solar drying system utilizes solar energy to heat up air and to dry any food substance loaded, which is not only beneficial in that it reduces wastage of agricultural produce and helps in preservation of agricultural produce, but it also makes transportation of such dried produce easy and promotes the health and welfare of the people. This paper presents the design and construction of a domestic passive solar food dryer. The dryer is composed of solar collector (air heater) and a drying chamber containing fruits and vegetables trays both being integrated together. The air allowed in through air inlet is heated up in the solar collector and heaters through the drying chamber where it is utilized in drying (removing the moisture content from the food substance or agricultural produce loaded). The design was based on the hybrid system. which is more reliable system is obtained for proper design specification. Locally available materials were used for the construction, iron body of container (painted), inlet and outlet fans (air ventilation system), mild steel metal sheet and net trays for wastage.

**Keywords:** Solar drying; Solar collector; Agriculture produce; Optimum temperature.

## I Introduction

Drying is one of the method of food preservation .Drying system preserve foods by removing enough moisture from food, the key is to remove spoilage .Drying of food, the key is to remove moisture as quickly as possible at a temperature that does not seriously affect the Flavour, texture and color of the food .Conventional method of drying such as sun

Drying, hot air convection drying requires more time to completely dry the product.

In this paper, we designed a dryer for fast and efficient drying of agricultural products. we use a reduced pressure environment (vacuum) for drying the agricultural products which enables the liquid to evaporate without elevating the temperature. combined with heat vacuum can be and effective method of drying. The smart dryer dries the products without losing its quality. The low cost of smart dryer makes it suitably for use in industrial as well as household purposes. The time required for drying is reduced as compared to conventional methods. The device mainly consists of a vacuum chamber, vacuum pump, heat source, temperature and humidity control system and some auxiliary systems. Compared with the conventional methods, this device just needs a small area and it can work under a completed indoor situation of natural environment. It shows high practical value and social economic benefits.

Drying is the oldest preservation technique of agricultural products and it is an energy intensive process. High prices and shortages of fossil fuels have increased the emphasis on using alternative renewable energy resources. Drying of agricultural products using renewable energy such as solar energy is environmental friendly and has less environmental impact.

Sun drying is a popular and economical method for drying of food materials in the developing countries. But drying rate is very low and dependent on weather conditions. Inferior quality of sun-dried products is mainly due to uneven drying, mixing of dust and dirt, and contamination with insects and microorganisms.

# Single Phase to Three Phase Converter

Gaurav Anil Kamble<sup>1</sup>, Digvijay vilas Patil<sup>2</sup>, Rushikesh Uttam Nalavade<sup>3</sup>

Raj Sarjerao Powar<sup>4</sup>, Tushar Ramchandra Patil<sup>5</sup>, Prof. A.M.Bhandare<sup>6</sup>

Student, Electrical Engineering Sanjeevan Engineering & Technology Institute<sup>12345</sup>

Professor, Electrical Engineering Sanjeevan Engineering & Technology Institute<sup>6</sup>

**Abstract - This paper presents a converter topology for driving a three-phase motor load from a single-phase supply. It consists of a rectifier and an inverter circuit. The front-end rectifier is to provide a DC link voltage through a split capacitor. The two-leg inverter converts this Dc link voltage into 3 phase supply. This converter can run a three-phase Induction motor which is much more efficient compared to a single-phase motor. In this paper, two closed-loop controllers are employed to achieve balanced output voltage. Among those two closed-loop controllers, one is for maintaining the DC link voltage constant and, the other is for inverter output. Therefore, the single-phase to three-phase converter brings the controllable output voltage as in a six-switch standard three-phase inverter. The front-end rectifier has the capability of active input current shaping. The designed converter model is simulated by using MATLAB Simulink software.**

## I Introduction

In the past, single-phase to three-phase conversion systems were made possible by the connection of passive elements capacitors and reactors with autotransformer converters. Such kind of system presents well know disadvantages and limitations. Both have the advantages of simple structure and reasonably low cost. Since the beginning of the solid state power electronics, the semiconductor devices were the major technology used to drive the power processors. Looking at the semiconductor devices used in the former controlled rectifiers and comparing them with the new technologies it makes possible to figure out the astonishing Development. Beyond the

improvement related to power switches, it was also identified a great activity in terms of the circuit topology innovations in the field of three phase to three-phase, single phase to single phase and three-phase to single phase conversion systems. The single-phase induction motor drives by the three-phase induction motor drives in some low-power industrial applications. When the three phase induction motor is driven by a single phase induction motor by rotary phase converters and autotransformer capacitor phase converters, this causes more loss as compared to the new this method. Motor drives constitute a predominant load for the agricultural sector. As most rural communities in the India are supplied with single-phase ac power, these drives have to be realized with single-phase motors, or with three phase motors (Induction Motors) driven by phase converters. Autotransformer capacitor phase converters, however, cannot easily obtain balanced output voltage with reasonable cost, and rotary converters are heavy and have significant no-load losses, also both topologies have high inrush current during motor start up. The three-phase induction motors have some advantages in the machine efficiency, power factor, and torque ripples compared to their single-phase counterparts. Though the precise control of single phase induction motor is less complex in comparison to the three phase induction motor, but when the torque requirement is considered then three phase induction motor is the best choice. The applications for these motors cover almost every stage of manufacturing and processing. It is not surprising to find that among all type of electric

## 11-STAGE MULTILEVEL INVERTER

Y.R. Naik<sup>\*1</sup>, A.M. Naik<sup>\*2</sup>, R.M. Mane<sup>\*3</sup>, A.R. Dorugade<sup>\*4</sup>,

S.E. Gurav<sup>\*5</sup>, A.B. Suryawanshi<sup>\*6</sup>

<sup>\*1</sup>Professor, Department Of Electrical Engineering, Sanjeevan Engineering And Technology Institute, Panhala, Maharashtra, India.

<sup>\*2,3,4,5,6</sup> Student, Department Of Electrical Engineering, Sanjeevan Engineering And Technology Institute, Panhala, Maharashtra, India.

### ABSTRACT

This topology consists of a full-bridge multi-level inverter, as an auxiliary circuit. The cascaded multilevel inverter is connected after the dc power supply. The main point of the auxiliary circuit is to generate half level dc supply voltage. According to the switch on-off conditions the output voltage levels should vary. The switch in auxiliary circuit must be properly switched with respect to the direction of the load current. From the above all discussion, we can eliminate considerable number of harmonics and we can reduce THD. we can deduce that in cascaded multilevel inverter topology with right switching angle and conduction period take from the calculation based on Fourier analysis. It has the several features such as reduced total harmonic distortion, near sinusoidal type output voltage waveform.

**Keywords:** Cascaded Multilevel Inverter, Reduced Harmonic Distortion.

### I. INTRODUCTION

In this paper, an experimental investigation has been carried out on single-phase multilevel inverter to obtain 11-level output voltage using cascaded four H-bridge units. The suggest system includes of four cascaded H-bridge MOSFET-based voltage sources inverters, a microcontroller-based Arduino imitation, four separate input DC sources and isolating circuit. The gate drive signals for MOSFETs of the four H-bridge inverters are generated by using ATmega microcontroller-based Arduino board. The microcontroller is used to reduce the difficulty of generating gate drive signals for multistory levels of inverter output voltage. 11-level output voltages have been exist from tentative works. It is found that the proposed system requires a smaller number of power switching devices and total harmonic distortion is reduced with increasing number of levels at the output voltage of the multilevel inverter. Power electronic converters, especially DC/AC inverters have been extending their range of use in industry because of their numerous advantages. They typically the stair-case type voltage waveform which has lower harmonic content. This project aims to extend the knowledge about the performance of 11 levels Cascaded H-Bridge multilevel inverter topology with Arduino. The PWM pulse will be generated by using Arduino. The output voltage is the summation of the voltage that is generated by all bridge. The switching angles can be pick out in such a way that the total harmonic distortion is decrease.

A new single phase cascaded multilevel inverter based on novel H-Bridge unit is used. The cascaded multilevel inverters have received special observation due to the reusability and clarity of the control. The cascaded multilevel inverters are mainly categorized into two parts: symmetric; with the equal magnitude for the dc voltage sources and asymmetric with different values of the dc voltage sources. By increasing the magnitude of dc voltage sources (Author-Ebrahim Babaei) [1]. In this project they use multilevel DC-AC inverter is proposed. The proposed multilevel inverter generates 7 level ac output voltage. The motive of multilevel topology is to reduce voltage rating of power switch. Therefore, it usually uses at high power application. By integrating output voltages in multilevel form, it has edge of low dv/dt, low input current deformity, and lower switching frequency. As a outcome of advantages of multilevel topology, several topologies have emerged in recent years (Author-Cheng-Han Hsieh) [2]. A cascaded H-Bridge with SPWM technique is presented. In Cascaded H-Bridge multilevel inverter, Number of H-Bridges are linked in series. Each H-Bridge having different DC supply which is to be acquire from any natural sources, ultra-capacitors, fuel cells or batteries to generate inverted ac output voltage. The advantage of these method is any capacitor or diode is not required for setting purpose and output waveform is like a sinusoidal in nature if number of level increases even we don't purify it. Multi-level inverters are used for high power as well as low power application in renewable energy sources such as wind, solar and

## EV CHARGING STATION

**Pramod Guarav\*<sup>1</sup>, Hemant Parab\*<sup>2</sup>, Piyusha Desai\*<sup>3</sup>, Aniket Sabhasad\*<sup>4</sup>,  
Atul Kumbhar\*<sup>5</sup>, Aniket Jambhale\*<sup>6</sup>, Omkar Patil\*<sup>7</sup>, Ajay Kadam\*<sup>8</sup>**

\*<sup>1</sup>Professor, Sanjeevan Engineering & Technology Institute, Panhala, Maharashtra, India.

\*<sup>2,3,4,5,6,7,8</sup>Students, Sanjeevan Engineering & Technology Institute, Panhala, Maharashtra, India.

### ABSTRACT

Solar charging station will be applied as a charger for electric powered vehicle. The solar panel will harvest energy from the solar that will be saved a battery % of automobile. In this undertaking erection of metallic shape with set up of solar panels became finished as in step with design.

Battery voltage for electric car is chosen as 48 volts. Charging voltage decided on on the idea of car battery Voltage. As per charging requirement 1000 watts, 3 panels of 330 watts are decided on with open circuit voltage as 46.3 volts and short circuit current as 9.24 Amp. To rate an electric powered automobile solar controller related among solar panels and battery package. This solar charging station can be commercialized to be positioned alongside a dual carriageway, or customized for an in-residence set up. Our group erected whole charging station, initiated from civil paintings, mechanical work and sooner or later electrical work. In this task work we obtained the information with interdisciplinary approach.

**Keywords:** Harvest, Erected, Interdisciplinary Etc.

### I. INTRODUCTION

Population wise India stands second inside the global. The primary source of earnings for maximum of the population remains farming in India. Current agriculture systems are operated manually which consumes huge amount of time, cash and power. In India there is massive difference among overall electricity deliver & demand to the farming. In many regions strength reduce down maintains for extra than 8hrs.[1] The current era makes use of fossil gasoline in many elements of India, which creates air pollution. So, it higher to use renewable supply of electricity authorities also encourages its use in various sectors, including automation irrigation gadget for the farming. Solar power is the maximum ample source of power inside the world solar electricity isn't always simplest an answer to todays strength crisis but also an environment pleasant shape of power photovoltaic generation is and efficient approach for the use of the sun strength.[2]

The environmental blessings of charging stations that commonly run on sun energy. Decreased dependence on fossil fuels, Every day jogging expenses honestly are for all intents and purposes lower in a suitable way.[3] The load on traditional grids also receives reduced in a main manner. Apart from this, pretty large scale implementation will boom employment opportunities without a doubt because of the need for educated human beings for installation, preservation and operation of those stations, virtually opposite to famous notion. Considering the blessings and the supply of the sort of system, pretty many corporations actually are making an investment on this concept, which within reason considerable. Tesla Motors, a subsidiary of Tesla, The critical part is building solar-powered charging stations in handy locations for its EV clients, which is quite considerable.[4] This assignment will similarly efforts to reducing our dependence on fossil fuels. If our charging station can price greater devices without having outside strength from the countrywide grid, it will likely be capable of lessen a number of the call for for electricity .Most of the peoples aware about the outcomes of the use of oil and herbal gas as a shape of strength. These strategies do create masses of electricity, however they may be non-renewable and they effects in broken the environment and earth environment.[5] The objective of this undertaking is to rate the vehicles environmentally secure in an effort to assist to lessen the demand of strength from different techniques. Our goal for this task will generate electricity from sun energy.

Our layout changed into confined to what assets had been available for us. Luckily, the majority of the device for this device became provided through our main and the Electrical Engineering Department. We firstly estimated a much larger system with a couple of sun panels and batteries to offer a quick price time for the electric car. [6]We ended up the use of best 444W, 12 sun panels and 40 Ah deep cycle battery. The primary components of

# Solar Panel Cleaner Using Vibrator and Air Blower for Desert Location

Pramod Guarav<sup>1</sup>, Amruta Salavi<sup>2</sup>, Sneha Pavane<sup>3</sup>, Pranil Sutar<sup>4</sup>, Ritika Hugar<sup>5</sup>, Priya Kamble<sup>6</sup>

Professor, Sanjeevan Engineering & Technology Institute, Panhala, Maharashtra<sup>1</sup>

Students, Sanjeevan Engineering & Technology Institute, Panhala, Maharashtra<sup>2,3,4,5,6</sup>

**Abstract:** *Solar panel is vulnerable to accumulated dust on its surface. The efficiency of the solar panel gradually decreases because of dust accumulation. Accumulation of dust and debris on even one panel in an array reduces their efficiency in energy generation considerably and emphasizes the need to keep the panel's surface as clean as possible. In this paper, a smart panel cleaning system for PV that provides a cost-effective and scalable solution for the removal of soil and dirt. It will automatically and remotely remove the dirt at a fraction of the cost of manual cleaning. In this paper, an Arduino based solar panel cleaning system is designed and implemented for dust removal. The proposed solar panel cleaner is waterless, economical and automatic. Two-step mechanism used in this system consists of an exhaust fan which works as an air blower and a vibration to detached the dust from the panel surface. Since, the system does not need water to clean solar panel, it avoids the wastage of water and effective in desert areas. In terms of daily energy generation, the presented automatic-cleaning scheme provides about 30% more energy output when compared to the dust accumulated PV module.*

**Keywords:** Solar panel, Cleaning, Efficiency, Dust, Air blower, etc.

## I. INTRODUCTION

To ensure sustainable environment, solar energy can play a vital role because it is an enormous, inexhaustible and green source of energy. In commercial level, 10 to 13% conversion can take place in solar cell. Efficiency of outdoor installed PV modules is reducing by 10 to 25% [1]. Efficiency of solar panel is decreases due to the dust. Dust is nothing but particulate matters. Dust consists of substance which present in air and includes smoke, fog. Inorganic and organic substances. Such substances are collected and dust can be formed. Also, dust can be included volcanoes vapors, forest fires, smoke, bacteria, storms, pollen and sand. For long period, dust can be present in air; atmospheric particles which are suspended solid can be included here. Through the wind movements, dust particles can be move and transfer to long distances. Atmospheric condition such as clouds, dust and temperature is affected to solar panel efficiency. Due to the atmospheric condition, all solar energy we can't be use. The mechanism primarily consists of air blower and vibration motion for cleaning on a glassy surface. In our project power loss can be less in amount. Our project is also self-reliant and for use it is very easy.[2]

A water-free automated cleaning service unit, comprising two DC geared motors, a lead screw, supporting shaft, rack and pinion mechanism, and the cleaning task is completed using blower and vibrator. These are hybrid actuators that provide rotary-to-linear motion through suitable mechanical transmission arrangements.[3]

Efficiency of solar panel is depending on the natural condition. So, it is necessary to take care parameters like dust, humidity and temperature. We used Atmega328 board for cleaning of solar panel. Our project includes design and implementation of solar panel cleaner. The actual goal is developed automatic solar panel cleaner. Manually solar panel can be clean but big disadvantage is risk of staff accidents, hard work and man power can be required. To overcome this all disadvantages, we can make automatic solar panel cleaner. It is more effective, smooth cleaning, and avoids the irregularities in the productivity due to the deposition of dust. Our system is work very smoothly.[4]

In recent years, photovoltaic technology has advanced fast for power generation from sunlight. There are mainly three cleaning methods, i.e., mechanical cleaning [5], nano-film based self-cleaning [6] and electrostatic cleaning [7,8]. Compared with other methods, mechanical method has a large dust removal force, rapid operation, good environmental adaptability and control performance.

---

## TRANSMISSION LINE MONITORING SYSTEM USING IOT

Sakshi Powalkar<sup>\*1</sup>, Pranali Kamble<sup>\*2</sup>, Mayuri Khilare<sup>\*3</sup>,

Akshata Kamble<sup>\*4</sup>, Arvind Bhandare<sup>\*5</sup>

<sup>\*1,2,3,4</sup>B.Tech Student, Electrical Engineering, Sanjeevan Engineering And Technology Institute  
Panhala, Kolhapur, Maharashtra, India.

<sup>\*5</sup>Asst. Professor, Electrical Engineering, Sanjeevan Engineering And Technology Institute  
Panhala, Kolhapur, Maharashtra, India.

---

### ABSTRACT

The electrical power system is growing and complexity in all sectors such as generation, transmission, distribution, and load systems. The detection and location of faults on power lines is essential to the protection and maintenance of a power system. In an electrical power system, a fault current is an abnormal electric current. In this system, some device uses like sensors to sense the current (in amp) and voltage (in volt) continuously of transmission line. Our system will detect if any voltage drops or overload on transmission line, if any these types of faults occur it can detect it and trip the line by using relay. Furthermore, if there are thefts occurs on line it can be detected automatically and intimated to the authority person with location by using Internet of Things. Location of theft is essential in case of power system. Detection of fault in the transmission line has been proposing by programming Arduino UNO and Arduino MEGA. Arduino senses the change in current and voltage as per programming and provides information to LCD. The device is measures incoming and outgoing values and find abnormalities with the help of sensors. Fast monitoring can help to protect power system. This is the concept of impedance method fault detection system. This fault and detection of theft is very fast.

**Keywords:** Internet Of Things, Arduino UNO, Arduino Mega.

---

### I. INTRODUCTION

Modern electric system is growing up exponentially [1]. Electrical power transmission line is a critical link between power generation plants and distribution to all electricity users. Length of transmission line is long and there is a possibility of fault occurrence. These faults cause giant damage to expensive equipment and damage stability [2]. So, fault should monitor quickly and isolate faulty line. It is important to protect the transmission system. Sensors can take accurate measurement of an electrical parameters and transfer information to IOT. Sending information to control room in appropriate time is a difficult challenge [3]. The theft of electricity is a big problem of power system. Theft is the major concern of the transmission and distribution losses in the supply of electricity [4]. All electricity companies face this issue and losses money every year due to theft. Electricity is being stealing with bypassing. This system is utilizing to overcome this type of losses of electricity, and it is very beneficial for the authorized agency to control its revenue loss. Proposed system is uses for identifying faults, thefts and if there is any fault occurs line will trip or isolate immediately, this work is complete by relay operation. It will protect transmission line against damage. Recommended system also detect theft, if there is any tapping online for electric power theft it will intimate to the authority person of control room with location by using Internet of Things (IOT) system. Detection of theft is integrating with IOT mechanism. Thus, we must take care of transmission line to reduce losses for efficient system, this proposed work, i.e., IOT based transmission line fault detection system may be the solution [5]. Most methods of fault detection and location based on measurements of electrical quantities provided by current and voltage transformers [6].

### II. METHODOLOGY

#### a) Current methods-

##### 1) Impedance based fault location method

In the impedance-measurement-based technique, the voltage and current during pre-fault and post fault are analyzed. Parameters of the line can be calculated with the transmission line model. Impedance-based methods required the following approach.

# Automatic Source Selector with Real Time Battery Parameter Monitoring

Akash Sadashiv Patekar<sup>1</sup>, Jadhav Dinesh Digambar<sup>2</sup>, Prajval Sanjay Patil<sup>3</sup>,

Manjunath Murlidhar Kamble<sup>4</sup>, Siddhant Maruti Khot<sup>5</sup>, Metakari Vishal Tukaram<sup>6</sup>

Student, Electrical Engineering Sanjeevan Engineering & Technology Institute<sup>1,2,3,4,5</sup>

Professor, Electrical Engineering Sanjeevan Engineering & Technology Institute<sup>6</sup>

**Abstract:** Source selection is the problem of identifying a subset of available data sources that best meet a user's needs. In this paper we propose a user-driven approach to source selection that seeks to identify sources that are most fit for purpose. The monitoring board measure the battery parameter using the divider circuit and series resistor And this measured data send to blink app by esp8266 wifi module. The Source Selector circuit using monitoring board measured parameter's Collected data is Compared with permissible limits in ATmega328P. According to this data ATmega328p gives signal to the relay to operate operate load.

## I Introduction

For a very long time, power outages, power interrupts and also unexpected routine power line maintenance is one of the major problems faced in industries, hospitals, offices, and homes whole over the world. For that case, this project provides an automatic operation of electrical power distribution systems; the rapid and reliable transfer of the system from one power source to another during specific events such as power outages, power interrupts, routine power line maintenance, to achieve the reliability of such systems. Electrical power supply is one of the primary essential needs of human life today, that is to say, without electrical power supply, most human works become stand still, postponed and even cancelled since most human actions are dependent on the electrical power supply. Furthermore, the need for power supply through access to electricity by the masses of the population of any country, both developed and developing countries is very important to the development of the economy of that particular country.

In other words, the power sector plays an essential role in the social economic development of any country. Why Is Battery Monitoring Important? Battery monitoring is important because it helps to predict the state of health and inevitable failure. Depending on battery type and application, Lead Acid batteries have a design life that can range

dramatically - from 5 to 20 years. That design life estimation is based on the battery being maintained in accordance with recommended practices, operating under ideal conditions and ensuring that any individual failing units are replaced before they impact the other units in the string. However, in most installations, those conditions are seldom met, and the actual life of a battery may be closer to half of the published design life. This potential for failure has been confirmed in a number of studies over the years. In fact, in one study into Data Center failures, the UPS Battery was responsible for over 50% of the reported outages. This data, and the uncertainty of most operating environments, confirms why battery monitoring is an essential part of maintaining. The project is designed to automatically supply continuous power to a load through one of the four sources of supply that are: solar, mains, generator, and inverter when any one of them is unavailable. Four switches are used for four respective sources. These are connected to a microcontroller of 8051 family that provides input signals to it. Whenever a switch is pressed it shows the absence of that particular source. A relay driver is used that receives microcontroller generated output and switches that particular relay to provide continuous power supply. A lamp is used as a load for demonstration purpose which draws power from main. When main fails to supply power, automatically next available source is used say inverter. If inverter fails then the next one is used and so on. An LCD is also used to display which source is being currently used for power supply. Therefore, this project provides an effective solution to provide an alternative power supply during frequent power cuts.

## II Literature Survey

The unreliable public power supply has led many to the alternative power supply sources .manual changeover switch system still remains the oldest changeover switch box used by majority of the electricity consumers. Manual changeover switch box separates the source between a system

## POWER GENERATION BY USING REVOLVING DOOR

N.S. Jadhav\*<sup>1</sup>, Abhishek Kupade\*<sup>2</sup>, Akshay Lad\*<sup>3</sup>

\*<sup>1</sup>Professor, Sanjeevan Engineering & Technology Institute, Panhala, Maharashtra, India.

\*<sup>2,3</sup>Students, Sanjeevan Engineering & Technology Institute, Panhala, Maharashtra, India.

### ABSTRACT

Humble world requires a ton of energy in various stages to run their occupation. So this handyman portrays the change of strong energy into mechanical energy which can be once more changed over into helpful electrical energy. The sustainable power and some unpredictable wellspring of energy likewise give revitalize economy to environment adjustment and lessen the utilization of petroleum derivative. The principal objective of this task is to plan and manufacture a smaller than expected rotating entryway which can create energy by intensifying the underlying RPM of entryway shaft that tackles human movement and transform it as power.

**Keywords:** Energy Generation, Dynamo, Gear, Pinion, Revolving Door.

### I. INTRODUCTION

Energy is crucial for the advancement of a country and it must be rationed in a most capable way. Not just the advances ought to be created to deliver energy in nearly climate amicable way however we need to get from all assortments of energizes and furthermore most extreme ought to be given to ration the energy assets in the strict turn of events. most effective way. Energy is a definitive component liable for both modern and horticulture. The environmentally friendly power innovation to fulfill the energy needs have been consistently expanding for the beyond couple of years, notwithstanding, the significant downsides related with inexhaustible. Energy frameworks are their powerlessness to ensure dependability and their lean nature. In this day and age meeting implies for delivering energy by customary strategies are declining step by step. Entryway based power age unit is uniquely intended to plan and manufacture the change unit for using the accessible non-customary energy source. That is immensely accessible energy in low force with adequate amount can be used. This machine changes over responding movement in to revolving movement. The rotational power is put away in flywheel and flywheel pivot alternator that produce power. The men coming on the way apply the effect power or push on the projected instrument. This effect pressure energy can be used to work the rack and pinion outfitting and through the train of pulleys can work the fly wheel, which stores the energy and uses it for ceaseless pivot of the generator working pulley and belt transmission framework. This wellspring of force can be utilized at the shopping centers, universities or lodgings and doubtlessly by the emergency clinics entryway working frameworks. Additionally by aggregating this low force power in batteries, it tends to be provided to the large towns or in towns where shortage of electric stock. This creation connects with implies for using the excess energy which is consumed by people utilizing spinning entryways, gates and such, by making that overflow energy be applied to the age of force for work in valuable way. From perception in huge structures furnished with spinning entryways, as likewise at rail route stations, ship houses, entertainment meccas and different spots whose doorways are protected by gates, a lot of labor supply, in overabundance of that required, is imparted as motivations to these gadgets for their turn, and that a portion of this overflow force be placed into valuable impact. Hence the creation comprises of mounting a power wheel co-pivotally with connection to a rotating component, like a spinning entryway or gate and giving a pawl on said power wheel for commitment by said rotating component to impart to the power wheel, the motivations got by the rotating component in the manual activity of the last option. Energy subsequently conferred to the power wheel is to be communicated there from by reasonable means either for the age of power or in any case for work reason man has required and involved energy at a rising rate for his food and prosperity since he came on the earth a couple a long time back. Crude man required energy principally as food. He determined this by eating plants or creatures, which he chased. Consequently he found fire and his energy needs expanded as he began to utilize wood and other bio mass to supply the energy needs for cooking as well with respect to keeping himself warm. With the progression of time, man began to develop land for agribusiness. He added another aspect to the utilization of energy by taming and preparing creatures to work for him. With additional interest for energy, man started to involve the breeze for cruising ships and for driving windmills, and the power of

Dr. J. J. Magdum Trust's  
Dr. J. J. Magdum College of Engineering, Jaysingpur  
Approved by AICTE, New Delhi, Recognised by Govt. of Maharashtra (D.T.E.) &  
Affiliated to Shivaji University, Kolhapur



# CERTIFICATE

OF PARTICIPATION

This is to certify that

VISHAL TUKARAM METKARI

Has participated in



**AICTE sponsored One Week Online Short Term Training Program (STTP)**

**On**

**"MACHINE LEARNING"**

**Under AICTE Quality Improvement Scheme (AQIS)**

Organized by

Department of Electronics and Telecommunication Engineering

Dr. J. J. Magdum College of Engineering, Jaysingpur, Maharashtra

from 24<sup>th</sup> to 29<sup>th</sup> January, 2022

  
Mr. M.M. Kolap  
STTP  
COORDINATOR

  
Mr. S.T. Jadhav  
H.O.D.  
E&TC

  
Dr. Mrs. S.B. Patil  
I/C PRINCIPAL &  
STTP COORDINATOR

  
Dr. S.S. Admuthé  
CAMPUS  
DIRECTOR



**Ambabai Talim Sanstha's**  
**Sanjay Bhokare Group of institutes, Miraj.**



Department of E&Tc has Organized Online STTP on

**"Internet of Things (IoT)"**

in collaboration with IETE on 27<sup>th</sup> Sept. 2021 to 02<sup>nd</sup> Oct. 2021

# Certificate

Of Appreciation

This is certified that Mr./Mrs./Ms. Vishal Tukaram Metkari IoT00173 of SETI, Panhala has attended one-week STTP on "Internet of Things (IoT)" arranged from 27<sup>th</sup> Sept. 2021 to 02<sup>nd</sup> Oct 2021 as Faculty.

  
P S Langde/Mrs. S S Kadam  
Co-Ordinator

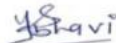
  
Mrs. V V Bhiungade  
HOD E&Tc

  
Dr. Mrs. S R Chougule  
IETE Chairperson,  
Subcenter Kolhapur

  
Dr. A C Bhagali  
Director

Dr. J. J. Magdum Trust's  
Dr. J. J. Magdum College of Engineering, Jaysingpur  
Approved by AICTE, New Delhi, Recognised by Govt. of Maharashtra (D.T.E.) &  
Affiliated to Shivaji University, Kolhapur



# CERTIFICATE

OF PARTICIPATION

This is to certify that

YOGESH RAMCHANDRA NAIK

Has participated in



AICTE sponsored One Week Online Short Term Training Program (STTP)

On

**"MACHINE LEARNING"**

Under AICTE Quality Improvement Scheme (AQIS)

Organized by

Department of Electronics and Telecommunication Engineering

Dr. J. J. Magdum College of Engineering, Jaysingpur, Maharashtra

from 24<sup>th</sup> to 29<sup>th</sup> January, 2022

  
Mr. M.M. Kolap  
STTP  
COORDINATOR

  
Mr. S.T. Jadhav  
H.O.D.  
E&TC

  
Dr. Mrs. S.B. Patil  
I/C PRINCIPAL &  
STTP COORDINATOR

  
Dr. S.S. Admuthé  
CAMPUS  
DIRECTOR



Ambabai Talim Sanstha's  
Sanjay Bhokare Group of institutes, Miraj.



Department of E&Tc has Organized Online STTP on

**"Internet of Things (IoT)"**

in collaboration with IETE on 27<sup>th</sup> Sept. 2021 to 02<sup>nd</sup> Oct. 2021

# Certificate

Of Appreciation

This is certified that Mr./Mrs./Ms. Naik Yogesh Ramchandra <sup>IoT00143</sup>  
of SETI, Panhala has attended one-week STTP on "Internet of Things  
(IoT)" arranged from 27<sup>th</sup> Sept. 2021 to 02<sup>nd</sup> Oct 2021 as Faculty.

  
P S Langde/Mrs. S S Kadam  
Co-Ordinator

  
Mrs. V V Bhiungade  
HOD E&Tc

  
Dr. Mrs. S R Chougule  
IETE Chairperson,  
Subcenter Kolhapur

  
Dr. A C Bhagali  
Director